

Wiring Hookup for ELK-TS07 Color Touchscreen 7"

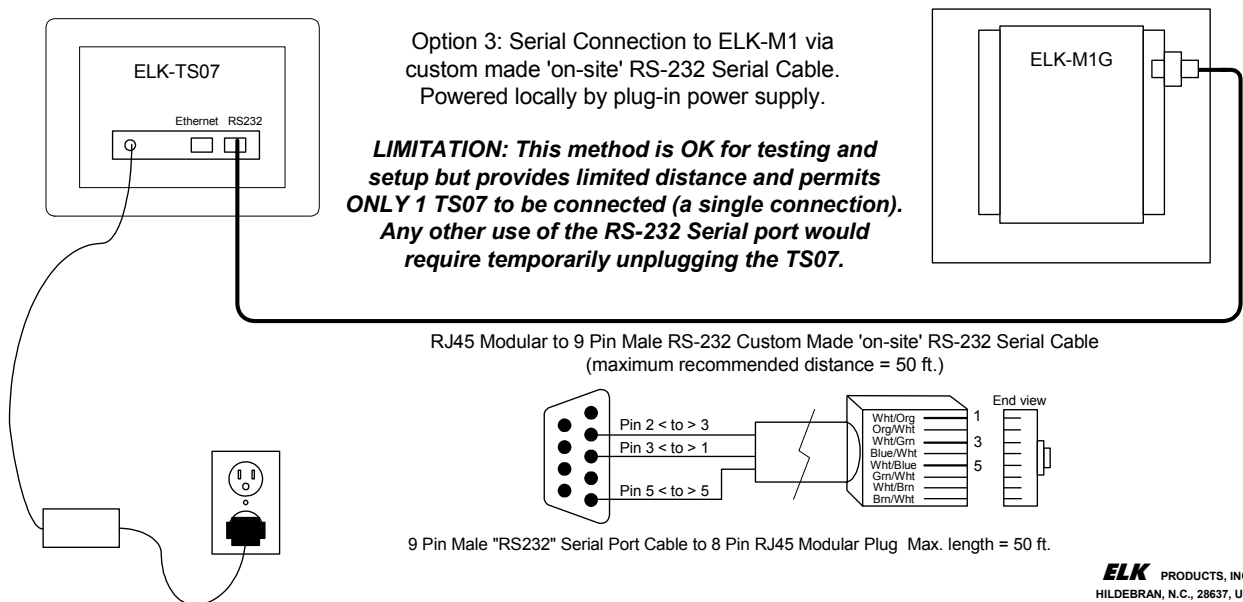
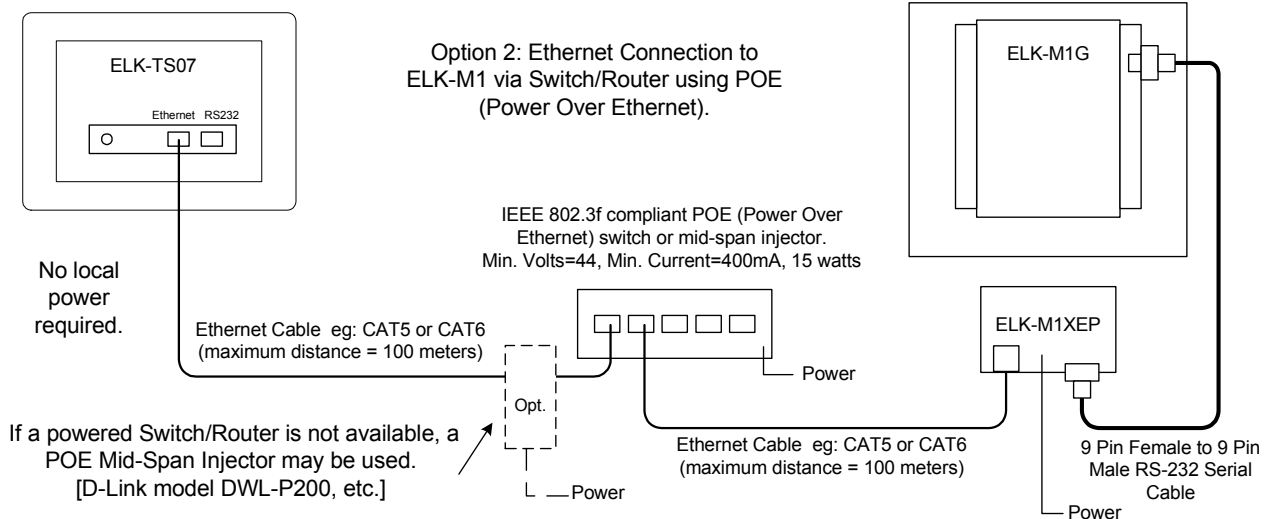
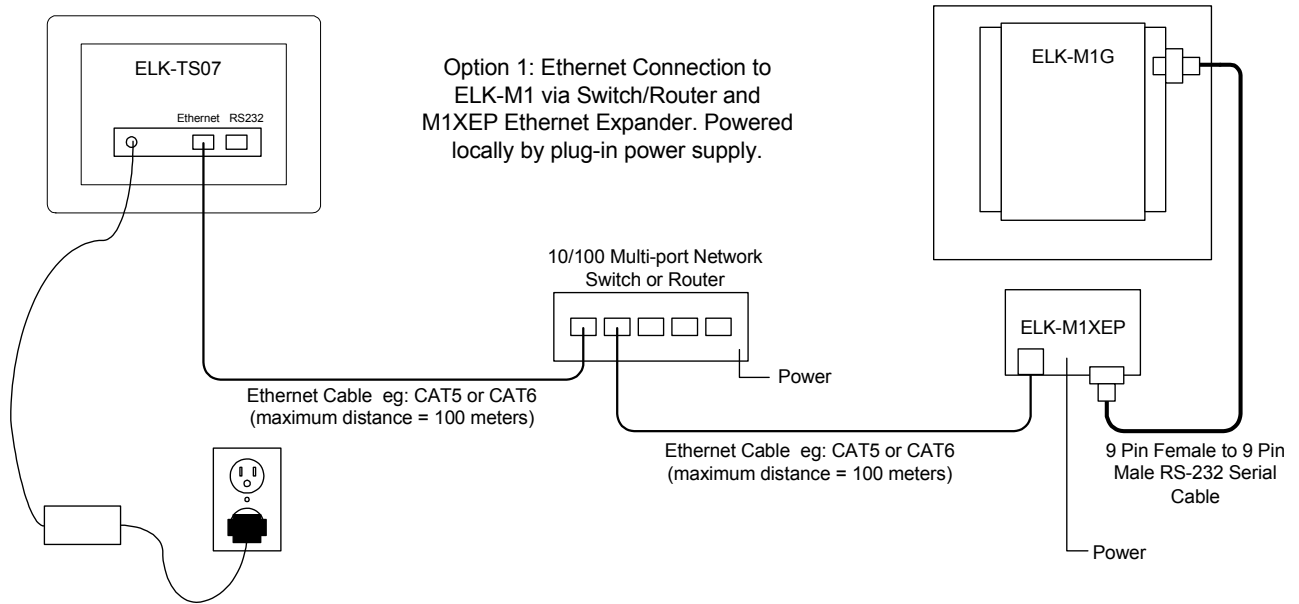

8"

Installation Template for ELK-TS07 Color Touchscreen Back Box

1. Use a stud finder or other type of wall probe to locate a suitable mounting location. Good detective work is important at this step to avoid where electrical, plumbing, or other utility pathways exist. The back box requires at least 1 5/8" clear depth.
2. Tape the template onto the wall surface making certain that it is level and plumb. Mounting height varies according to personal preference.
3. Use a sharp utility knife to cut along the four (4) straight dotted lines. This will transfer the template pattern to the wall.
4. Remove template and CAREFULLY cut along the inside of the lines scored by the utility knife. Proceed SLOWLY to avoid burring or splintering the wall surface.
5. The final cutout should resemble the picture to the right.
KEEP IN MIND...it is easier to make the hole a little larger than it is to put material back once it has been removed!

6 5/16"